



**SLASHA**  
**OPERATORS MANUAL**

PM-000084-D

# 1 TO THE PURCHASER

Congratulations on the purchase of your new DIGGA Slasher! This product was carefully designed and manufactured to give you years of dependable service. To keep it running efficiently please read the instructions in the manual to keep it in top working condition.

Be sure to observe all safety precautions and maintenance procedures as described in this manual.

No responsibility will be taken by Digga for any omissions or errors in this manual as all data is correct at time of print, however Digga reserve the right to revise this manual without further notice.

The Slasher has mutlifit mounting. Please contact your DIGGA dealer for any further information pertaining to this product or for further information on other Digga products.

## ABOUT THIS MANUAL

This manual has been designed to help you do a better, safer job. **Read this manual carefully and become familiar with its contents.** Remember; never let anyone operate this unit without reading the "Safety Precautions" and "Operating Instructions" sections of this manual. Unless noted otherwise, right and left sides are determined from the position of the operator when behind the product facing forward.

<b>DIGGA</b>	<b>CE</b>
www.digga.com	
Model	<input type="text"/>
Serial No.	<input type="text"/>
Flow (max)	<input type="text"/>
Pressure (max)	<input type="text"/>
Power	<input type="text"/>
Weight	<input type="text"/>
Approximate Oil Capacity:	<input type="text"/>

DE-000108 MADE IN AUSTRALIA

Your Digga Slasher is a **user non serviceable part. Unauthorised disassembly will void warranty.** All service and warranty must be performed by an authorised DIGGA service agent. Contact your local Digga dealer for details. To facilitate warranty or service, record the model and serial number of your unit in the space provided on this page.

This information may be obtained from the identification plate located on the product.

**IMPORTANT: WHEN SERVICING OR ASSEMBLING YOUR PRODUCT, REMEMBER TO USE ONLY GENUINE DIGGA REPLACEMENT PARTS. SUBSTITUTE PARTS MAY NOT MEET THE STANDARDS REQUIRED FOR SAFE, DEPENDABLE OPERATION. USE OF NON GENUINE DIGGA PARTS WILL VOID WARRANTY AND DIGGA WILL ACCEPT NO LIABILITY WHAT SO EVER FOR CONSEQUENTIAL OR SPECIAL DAMAGES.**

MODEL \_\_\_\_\_

SERIAL NUMBER \_\_\_\_\_

DATE PURCHASED \_\_\_\_\_

The parts department needs this information to insure accurate parts can be sent to the authorised service agent.

	PAGE
1 TO THE PURCHASER.....	3
2 TABLE OF CONTENTS.....	4
3 PREPARATION FOR USE.....	5
4 SAFETY PRECAUTIONS.....	6
5 SAFETY - WORKING WITH THE ATTACHMENTS.....	11
6 INSTALLATION AND OPERATING INSTRUCTIONS.....	12
7 SPARE PARTS.....	16
8 MAINTENANCE.....	18
9 SAFETY STICKER LOCATION.....	20
10 TROUBLESHOOTING.....	22
11 TECHNICAL SPECIFICATIONS.....	23
12 WARRANTY.....	24

### MODELS COVERED IN THIS MANUAL

SLASHA STANDARD MODELS		SLASHA EXCAVATOR MODEL / SIDE SHIFT
SL-000225	SL-000228	SL-000153
SL-000227	SL-000170	SL-000165
SL-000103	SL-000002	
SL-000267	SL-000255	
SL-000283		

### 3 PREPARATION FOR USE

To avoid any inconvenience before operation, please check that you have received the following items which you have ordered. Items may differ depending on the type of machine your Slasher is to be fitted to:

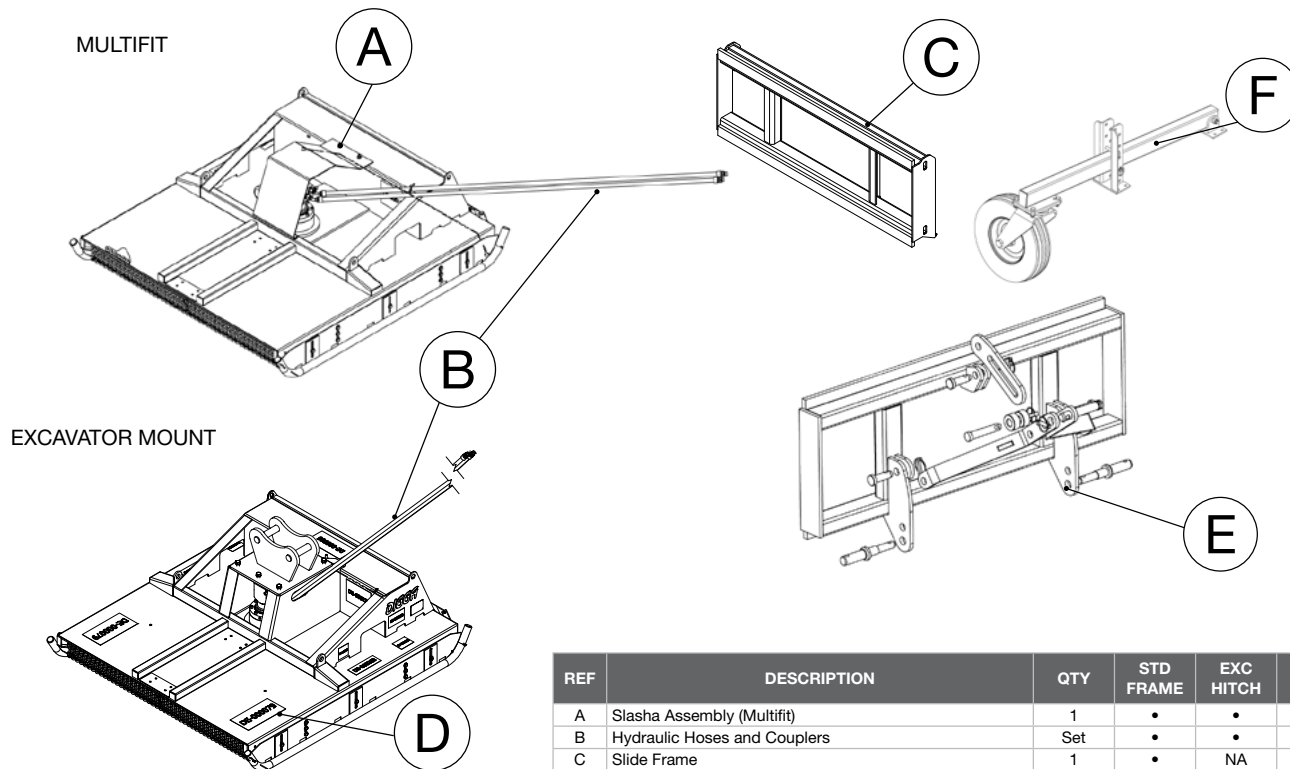

REF	DESCRIPTION	QTY	STD FRAME	EXC HITCH	SIDE SHIFT
A	Slasha Assembly (Multifit)	1	•	•	•
B	Hydraulic Hoses and Couplers	Set	•	•	•
C	Slide Frame	1	•	NA	NA
D	Slasha Assembly (Excavator Mount)	1	NA	•	•
E	Frame Assembly 3PT Linkage	1	NA	NA	•
F	Removable adjustable jockey wheel (Optional)	1	•	•	•

**TAKE NOTE! THIS SAFETY ALERT SYMBOL FOUND THROUGHOUT THIS MANUAL IS USED TO CALL YOUR ATTENTION TO INSTRUCTIONS INVOLVING YOUR PERSONAL SAFETY OR OTHERS. FAILURE TO FOLLOW THESE INSTRUCTIONS CAN RESULT IN INJURY OR DEATH.**

**THIS SYMBOL MEANS:**



**ATTENTION!  
BECOME ALERT!  
YOUR SAFETY IS INVOLVED!**

**SIGNAL WORDS:** Note the use of signal words DANGER, WARNING, and CAUTION with the safety messages. The appropriate signal word for each has been selected using the following guidelines:

**DANGER:** Indicates an imminently hazardous situation, which if not avoided, will result in death or serious injury. This signal word is to be limited to the most extreme situations, typically for machine components which, for functional purposes, cannot be guarded.

**WARNING:** Indicates a potentially hazardous situation, which if not avoided, could result in death or serious injury, and includes hazards that are exposed when guards are removed. It may also be used to alert against unsafe practices and indicate potential failure or damage to equipment.

**CAUTION:** Indicates a potentially hazardous situation, which if not avoided, may result in minor or moderate injury. It may also be used to alert against unsafe practices.

This section is composed of various warnings and safety tips. **Read and learn all the information in this section before you attempt to use your attachment.** Also read your machines owner's manual before using your equipment. This knowledge will help you operate your unit safely. **Do not take this information lightly, it is presented for your benefit and for the benefit of others working around you.**

The "Safety Alert Symbol"  will be used throughout this manual. It will appear with the word **DANGER, WARNING, or CAUTION,** and a safety message pertaining to the specific topic being covered. Take the time to read these messages as you come across them.

## 4 SAFETY PRECAUTIONS - GENERAL INFORMATION

### WARNING



#### **KNOW WHERE UTILITIES ARE**

Observe overhead electrical and other utility lines. Be sure equipment will clear them. When digging, call DIAL BEFORE YOU DIG ON 1100 (in Australia), or your local UTILITIES location service provider for location of buried utility lines, gas, water, and sewer, as well as any other hazard you may encounter.

#### **EXPOSURE TO RESPIRABLE CRYSTALLINE SILICA DUST ALONG WITH OTHER HAZARDOUS DUSTS MAY CAUSE SERIOUS OR FATAL RESPIRATORY DISEASE.**

It is recommended to use dust suppression, dust collection and if necessary personal protective equipment during the operation of any attachment that may cause high levels of dust.

### WARNING



#### **REMOVE PAINT BEFORE WELDING OR HEATING**

Hazardous fumes/dust can be generated when paint is heated by welding, soldering or using a torch. Do all work outside or in a well ventilated area and dispose of paint and solvent properly. Remove paint before welding or heating. When sanding or grinding paint, avoid breathing the dust. Wear an approved respirator. If you use solvent or paint stripper, remove stripper with soap and water before welding. Remove solvent or paint stripper containers and other flammable material from area. Allow fumes to disperse at least 15 minutes before welding or heating.

### WARNING



#### **END OF LIFE DISPOSAL**

At the completion of the useful life of the unit, drain all fluids and dismantle by separating the different materials (rubber, steel, plastic, etc.). Follow all federal, state and local regulations for recycling and disposal of the fluid and components.

#### **OPERATING THE SLASHER**

### WARNING



- An operator must not use drugs or alcohol, which can change his or her alertness or coordination. An operator taking prescription or over-the-counter drugs should seek medical advice on whether or not he or she can safely operate equipment.
- All bystanders should be kept a minimum of 15 meters (50 feet) away from the working area of the Slasher.
- Do not allow Site workers to climb or ride on Slasher at any time, including while stationary, in operation or being moved.
- Operate only from the operator's station.
- Avoid steep hillside operation which could cause the machine to overturn. Consult your machines operator's and safety manuals for maximum incline allowable.
- Flow and pressure gauges, fittings, and hoses must have a continuous operating pressure rating of at least 25% higher than highest pressures of the system.

### WARNING



#### OPERATING THE SLASHER (CONTINUED)

- Reduce speed when driving over rough terrain, on a slope, or turning, to avoid overturning the vehicle.
- Travel only with the Slasher in a safe transport position to prevent uncontrolled movement. Drive slowly over rough ground and on slopes.
- Do not drive close to ditches, excavations, etc., cave in could result.
- Before exiting the machine, lower the attachment to the ground, apply the parking brakes, turn off the prime mover's engine, and remove the key.
- Do not smoke when refueling the prime mover. Allow room in the fuel tank for expansion. Wipe up any spilled fuel. Secure cap tightly when done.

### WARNING



- Remove the Slasher from the prime mover before transporting to and from the job site.
- The Slasher must be stopped before making adjustments to the attachment.
- All Slashing operations must be stopped in the event of local thunderstorm, or lightning activity. During operation, weather conditions shall be monitored: operations shall cease during electrical storms or when electrical storms are imminent.
- Slasher shall be used only for their designed intent and shall not be loaded beyond their rated capacity. Overloading or exceeding the manufacturers specifications will void all warranty.

### WARNING



#### STORAGE OF THE SLASHER

- Seal hydraulic couplers from contaminants and secure all hydraulic hoses off the ground to help prevent damage.
- Clean the unit thoroughly, removing all mud, dirt, and grease.
- Inspect for visible signs of wear, breakage, or damage. Order any parts required and make the necessary repairs to avoid delays upon removal from storage.
- Tighten loose nuts and cap screws.
- Replace decals that are damaged or in unreadable condition.
- Store unit in a dry and protected place. Leaving the unit outside will materially shorten its life.

## 4 SAFETY PRECAUTIONS - GENERAL INFORMATION

### **WARNING** GROUND PERSONNEL AND BYSTANDERS



- Be alert to others in the work area. Be sure others know when and where you will be working. Make sure no one is behind equipment or within 15 meters (50 feet) of it operating.
- Loose fitting clothing, long hair, jewellery and equipment which might become entangled in moving equipment are prohibited while working near the Slasher.
- Operators, helpers, and other personnel working near Slasher must wear steel-toe safety shoes, safety glasses, and hard hats as a minimum. Hearing protection, respirators, and personnel protective clothing will be specified in the site-specific Health and Safety Plan.

### **WARNING**



### **MAINTAINING THE SLASHER**

- Before performing maintenance, lower the attachment to the ground, apply the parking brakes, turn off the engine, and remove the key.
- Never adjust a relief valve for pressure higher than recommended by the machine's manufacturer.

### **TRANSPORTING**

Follow all local government regulations that may apply along with recommended tie down points and any equipment safety precautions at the front of this handbook when transporting your attachment.

### **TIE DOWN POINTS**

- Tie down points are identified by tie down decals where required. Securing to trailer at other points is unsafe and can damage attachment.
- Do not attach tie down accessories around cylinders or in any way that may damage hoses or hydraulic components.
- Attach tie down accessories to unit as recommended.
- Check unit stability before transporting.

### **WARNING**



Verify that all tie down accessories (chains, slings, ropes, shackles, etc.) are capable of maintaining attachment stability during transporting and are attached in such a way to prevent unintended disengagement or shifting of the unit. Failure to do so could result in serious personal injury or death.



## 4 SAFETY PRECAUTIONS - GENERAL INFORMATION

### TO THE OPERATOR

The primary responsibility for safety with this equipment falls to the operator. Make sure that the equipment is operated only by trained individuals that have read and understand this manual. Don't hurry the learning process or take the unit for granted.

It is the skill, care, common sense, and good judgement of the operator that will determine how efficiently and safely the job is performed. Know your equipment before you start. Know its capabilities and how to operate all the controls.

Visually inspect your equipment before you start, ensure correct assembly and installation of the attachment and never operate equipment that is not in proper working order.

Practice the operation of your new attachment and become familiar with the controls and the way it handles on your machine. If there is any portion of this manual or function you do not understand, contact your local authorized dealer or the manufacturer.

1. Never operate the Attachment without first reading and understanding the entire operator's manual.
2. Do not paint over, remove or deface any safety signs or warning decals on your equipment.
3. Follow all safety decals. Keep them clean and replace them if they become worn, damaged or illegible.
4. Know your equipment inside and out. Know how to operate all controls and know emergency shut down procedures.
5. Keep all stepping surfaces, pedals, and controls free from dirt, grease and oil. Keep equipment clean to help avoid injury from slipping or a fall when getting on or off equipment.
6. Operate the attachment only in daylight or with sufficient artificial light.
7. Always carry loads close to the ground. Do not step off machine platform with load raised.
8. Turn off engine before performing maintenance. All maintenance can be performed with the machine arms lowered. If lift arms must be left raised for any reason, use a positive lift arm lock to secure the arms in place. Serious damage or personal injury could result from lift arms accidentally lowering.
9. Do not exceed rated operating capacity of the host machine, as machine may become unstable resulting in loss of control.
10. Always lower the loader arms or machine boom to the ground, shut off the engine and remove the key before getting off the unit.
11. Never use the Slasher on a machine that is not equipped with a cab or ROPS, and operator restraints (seat belts or equivalent devices).

## 5 SAFETY - WORKING WITH THE ATTACHMENT

### **WHEN MOUNTING THIS PRODUCT TO YOUR MACHINE**

- Refer to the operator's manuals of your machine, and your quick-attach for special or detailed mounting instructions.
- This product should fit onto the tool bar/quick-attach mechanism of your machine.
- If this product does not fit properly, contact your Digga Dealer before operating.
- Where 'Dead Man' connections are connected or installed it is illegal to disengage, tamper with or remove them.

### **WHEN ADJUSTING, SERVICING OR REPAIRING THIS PRODUCT**

- Make no modifications to your Slasher.
- When making repairs use only authorised Digga service agents, and genuine Digga parts.
- Replacement parts must also have safety signs attached.

The Digga Slasher receives its power from the parent machine through the auxiliary valve circuit with quick release couplers normally located on the machine arm near the front. Hook up hoses to auxiliary hydraulics.

Engine must be shut off. Pressure may need to be released.

Ensure your machine flow, pressure and load ratings do not exceed the maximum ratings stated on your slasher serial tag. It is the responsibility of the operator to ensure the unit's maximum rated flows, pressure and load ratings are never exceeded. Exceeding these will void warranty.

**IF YOU ARE IN DOUBT CONTACT YOUR NEAREST DIGGA DEALER FOR ASSISTANCE.**



**SAFETY FIRST!! READ AND UNDERSTAND THE SAFETY INSTRUCTIONS BEFORE BEGINNING ANY SLASHER MOUNTING.**

### SLASHER INSTALLATION

1. Place the product on a firm, levelled surface that is large enough to safely accommodate this product, loader and all workers involved in the mounting process.
2. Be sure all connection points are properly secured.
3. Refer to the operator's manual(s) for your loader quick attach and follow the mounting instructions contained there in.
4. Carefully raise the loader arms and cycle the tilt cylinder to check clearance and to verify that all mounting procedures have been successfully completed.

### SLASHER HYDRAULIC CONNECTIONS

1. Attach the quick couplers to your loader as per the instruction in your machine operator's manual.
2. Carefully raise the loader arm and cycle the tilt cylinders to check hose clearance and check for any interference.
3. To assure optimum motor life, run hydraulic motor for hour on approx. 1/3 RPM before application of full load.



**NOTE: IT IS IMPORTANT TO MAKE SURE THE LOCKING MECHANISM ON YOUR QUICK ATTACH IS ENGAGED, THEREFORE LOCKING THE ATTACHMENT ONTO THE MACHINE.**



**DO NOT LOCK AUXILIARY HYDRAULICS OF YOUR MACHINE IN THE "ON" POSITION. FAILURE TO OBEY THIS WARNING COULD RESULT IN DEATH OR SERIOUS INJURY.**

## 6 INSTALLATION AND OPERATING INSTRUCTIONS



**SAFETY FIRST! READ AND UNDERSTAND THE SAFETY INSTRUCTIONS BEFORE BEGINNING ANY SLASHING OPERATING.**



**FAILURE TO OBEY THE FOLLOWING PROCEDURE COULD RESULT IN DEATH OR SERIOUS INJURY.**

### **NEVER LIFT THIS PRODUCT:**

- More than 500mm off the ground whilst blades are spinning OR to a height where visibility is obstructed, which ever is lower.
- DO NOT raise the Slasher in a vertical position whilst the blades are spinning.
- The Slasher is not designed to be used as a hedge trimming tool.

## **SLASHER OPERATION**

### **GENERAL INFORMATION**

The Digga Slasher is perfect for cutting tall grass and brush. The Slasher attaches to the toolbar/quick attach mechanism for your loader or quick hitch of your excavator (depending upon which version you ordered). Due to this arrangement, thorough knowledge of the loader or excavator control is necessary for machine operation. Read and understand your loader or excavator's operator's manual before attempting to use the Slasher.

### **OPERATING TIPS**

- Increase the life of your bidirectional blades by cutting brush in one direction and cutting grass and smaller vegetation in another (This will keep the blades sharp for cutting grass).
- If your preferred direction of blade rotation is not set up correctly for your loader "default", the hoses may be reversed at the loader end.



**DANGER! ROTATING BLADE HAZARD, STAY BACK LOOSE OBJECT CAN BE DISCHARGED!**

**CUTTING OPERATION**

1. Raise the back of the unit off the ground approx. 100mm to allow the material to clear from under the cutter deck as you travel forward.
2. Place the front skid shoe 25mm-50mm off the ground. This is the preferred position for cutting grass and heavy vegetation.



**CAUTION: NEVER DRIVE YOUR LOADER WITH THE FRONT OF THE SLASHER TO THE POINT THAT YOUR VIEW IS OBSTRUCTED. ALWAYS MAKE SURE THAT YOU CAN SEE WHAT YOU ARE CUTTING.**

**CAUTION: CHECK THE WORK AREA. NEVER OPERATE THE CUTTER IN POPULATED AREAS WHERE THROWN OBJECTS COULD INJURE PERSONS OR DAMAGE PROPERTY.**

**CAUTION: NEVER RAISE THE SLASHER AND EXPOSE YOURSELF OR ANYONE ELSE TO THE ROTATING BLADES. IF YOU CAN SEE THE BLADES, THEN THE BACK OF THE UNIT IS RAISED TOO HIGH.**

3. Confirm the bystanders are at least a minimum safe distance of 15m (50ft) from the equipment.
4. Start Engine.
5. Ensure that the auxiliary hydraulic valve to power the Slasher is disengaged and that the engine is at idle.
6. Engage the auxiliary hydraulic valve. Increased the engine speed to the desired speed.
7. Proceed to commence slashing and comply with all safety procedures.

**CUTTING LARGE BRUSH**

1. When cutting large brush, tilt the front of the Slasher up 300-600mm (1-2ft.).
2. Slowly drive into the bush and use the tilt function of the loader to bend/push the brush over. As the brush bends the blades will cut it off.
3. The brush can now be mulched by driving the loader forward several feet and then reversing back, hence mulching any brush which may not have been mulched on the forward movement.
4. Repeat if necessary.



**CAUTION: NEVER RAISE THE SLASHER AND EXPOSE YOURSELF OR ANYONE ELSE TO THE ROTATING BLADES. IF YOU CAN SEE THE BLADES, THEN THE BACK OF THE UNIT IS RAISED TOO HIGH.**



**CAUTION: ALWAYS CHECK THAT THE CHAINS ARE IN GOOD WORKING CONDITIONS AND THAT THE SAFETY WIRE IS FIRMLY ATTACHED. NEVER REMOVE THE CHAINS FROM THE SLASHER. FAILURE TO OBEY THESE INSTRUCTIONS COULD RESULT IN SEVERE INJURY.**

## 6 INSTALLATION AND OPERATING INSTRUCTIONS

### REMOVAL AND STORAGE

1. Set the attachment on the ground and follow the standard shut down procedure in your loader operators manual.
2. With the loader OFF, disengage the attachment lock pins, release hydraulic pressure from the auxiliary hydraulic system and disconnect the hydraulic couplers from the loader.
3. Start the machines engine and make sure that the lift arm is lowered and in contact with the loader frame.
4. Roll the attachment mechanism forward and slowly back up until the attachment is free from the machine.
5. Remove and store the attachment in a dry and protected place. Leaving the Slasha outside will materially shorten its life.

### WHEN ATTACHMENTS NOT ON PARENT MACHINE:

It is a requirement of the Australian Work place Health and Safety act 1995 that safe systems of work are employed when handling any attachments. Complete compliance with Workplace Health and Safety issues is compulsory and all due care and attention must be observed at all times in any method of moving, transporting or storing any such device when not attached to a parent machine. We recommend attachments are well secured when being moved or in transit and furthermore prior to moving, storing, loading/unloading or parking it is suggested that the attachment is strapped/secured to a pallet or enclosed in a suitable container to minimise any movement or loss of the load during such activity. NO responsibility for loss or damage to persons or property in any regard can be attributed to Digga.

### TRANSPORTING THE ATTACHMENT

1. Follow all federal, state and local regulations when transporting the unit on public roads.
2. Use extra care when loading or unloading the machine onto a vehicle. Disconnect hydraulic couplers during transportation.



**CAUTION: IF THE SLASHA IS TO BE LIFTED ONTO A VEHICLE, USE THE LIFTING LUGS PROVIDED ON THE UNIT.**

## SLASHER - BLADE ASSEMBLY

1250MM

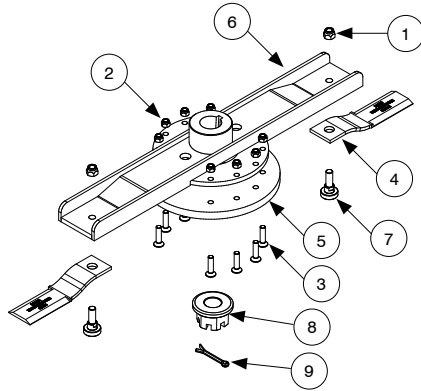

1500MM

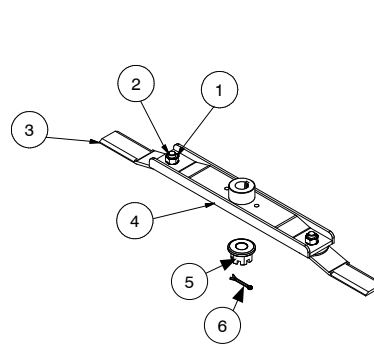

1800MM

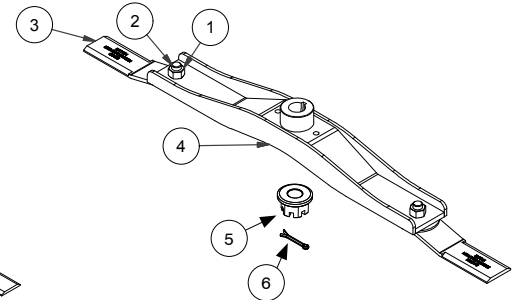

## PARTS LIST

ITEM	QTY	PART NUMBER	DESCRIPTION
1	2	FA-000095	NUT NYLOC 5/8 UNC GR5 ZP
2	8	FA-000189	NUT NYLOC M12 ZINC PLATED
3	8	FA-000487	SCREW FLAT HEAD SOCKET M12 X 50 G10.9ZP
4	2	ML-000243	MINI SLASHER - CUTTING BLADE
5	1	ML-000248	MINIS SLASHER - FLY WHEEL
6	1	SL-000216	SLASHER - 1250MM STRONG BACK SUPPORT WELDMENT
7	2	SL-000243	SLASHER - CUTTING BLADE BOLT - 1250MM BLADE
8	1	FA-000431	NUT-CASTALLATED
9	1	PI-000050	SPLIT PIN

## PARTS LIST

ITEM	QTY	PART NUMBER	DESCRIPTION
1	2	FA-000233	NUT NYLOC 1 1/8 IN UNF ZINC PLATED
2	2	SL-000044	SLASHER - CUTTING BLADE BOLT
3	2	SL-000117	SLASHER - SHORT CUTTING BLADE
4	1	SL-000155	SLASHER - STRONG BACK SUPPORT WELDMENT
5	1	FA-000431	NUT-CASTALLATED
6	1	PI-000050	SPLIT PIN

## PARTS LIST

ITEM	QTY	PART NUMBER	DESCRIPTION
1	2	FA-000233	NUT NYLOC 1 1/8 IN UNF ZINC PLATED
2	2	SL-000044	SLASHER - CUTTING BLADE BOLT
3	2	SL-000117	CUTTING BLADE
4	1	SL-000251	SLASHER - STRONG BACK SUPPORT WELDMENT
		SL-000250	ENTIRE BLADE ASSEMBLY
5	1	FA-000431	NUT-CASTALLATED
6	1	PI-000050	SPLIT PIN

## 7 SPARE PARTS

For further information on spare parts please contact one of the Digga sales office below your closest authorised Digga Dealer.

### **DIGGA INTERNATIONAL SALES OFFICES**

#### **ASIA PACIFIC**

##### **DIGGA HEAD OFFICE - BRISBANE**

4 Octal St, Yatala QLD 4207

**PH:** (07) 3807 3330

**EMAIL:** [info@digga.com](mailto:info@digga.com)

##### **DIGGA NEW SOUTH WALES**

Unit 2, 36 Bluett Drive,  
Smeaton Grange NSW 2567

**PH:** 1300 2 DIGGA

**EMAIL:** [nsw@digga.com](mailto:nsw@digga.com)

##### **DIGGA VICTORIA**

27 Metcalf Street,  
Dandenong, VIC 3175

**PH:** 1300 2 DIGGA

**EMAIL:** [vic@digga.com](mailto:vic@digga.com)

**WEB:** [www.digga.com](http://www.digga.com)

#### **NORTH AMERICA**

##### **DIGGA NORTH AMERICA**

2325 Industrial Parkway SW  
Dyersville IA 52040

**PH:** + 1 563 875 7915

**WEB:** [www.diggausa.com](http://www.diggausa.com)

**EMAIL:** [info@diggausa.com](mailto:info@diggausa.com)

#### **EUROPE**

##### **DIGGA EUROPE**

Unit 6, Smitham Bridge Road  
Hungerford Trading Estate,  
Hungerford, Berkshire RG17 0QU  
England, United Kingdom

**PH:** +44 (0) 1488 688 550

**WEB:** [www.diggaeurope.com](http://www.diggaeurope.com)

**EMAIL:** [info@diggaurope.com](mailto:info@diggaurope.com)





**SAFETY FIRST!! READ AND UNDERSTAND THE SAFETY INSTRUCTIONS BEFORE BEGINNING ANY SLASHA MAINTENANCE.**

### BEFORE FIRST USE

Inspect the attachment for shipping damage. If damage does exist, do not operate until the damaged parts have been replaced or repaired.

### BEFORE EACH USE

- Make sure that all nuts and bolts are in place and properly tightened.
- Make sure that all other fasteners are in place and are performing their specified function.
- Make sure that all hydraulic fittings are tightened and that there are no leaks in any fittings or hoses.
- Make sure that all safety signs are in place, are clean, and are legible. (SEE THE SAFETY SIGN SECTION)
- Replace any damaged parts and excessively worn parts.
- Grease all lubrication points.
- Check your fold back cutting blades for wear and replace as needed.
- Ensure chains are in good working condition and that tie wires and binding chains are intact and secure. Never remove chains from Slasher



## WARNING!

**If injured by injected fluid, see a doctor at once. If your doctor is not familiar with this type of injury, ask him to research it immediately to determine proper treatment.**

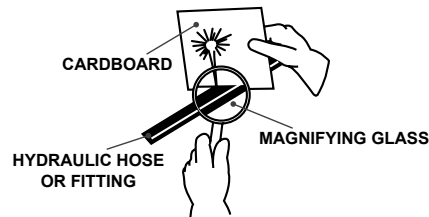

Escaping fluid under pressure can have sufficient force to penetrate the skin causing serious personal injury. Fluid escaping from a very small hole can be almost invisible. Use a piece of cardboard or wood, rather than hands to search for suspected leaks.

Keep unprotected body parts, such as face, eyes, and arms as far away as possible from a suspected leak. Flesh injected with hydraulic fluid may develop gangrene or other permanent disabilities.



### IMPORTANT: OIL CHANGE SCHEDULE

THE GEARBOX OIL CAPACITY IS ENGRAVED ONTO THE SERIAL TAG LOCATED ON THE SIDE OF THE SLASHER.

#### Initial (Bed-in) oil change:

- \* The first oil change must be carried out within the first 30 hours of operation. Thereafter, every 300 hours.
- ▲ The first oil change must be carried out within the first year of operation. Thereafter, every 3 years.

	* SLASHERS WITH GEARBOX	▲ SLASHERS WITH DIRECT DRIVE
FIRST OIL CHANGE	Within the first 30 hours of use	Within the first year
2ND OIL CHANGE PLUS SUBSEQUENT OIL CHANGES	After 300 hours of use thereafter	Every 3 years thereafter

SLASHER MODEL	OIL TYPE	OIL QTY (ml)
*1250MM MULTIFIT (SL-000227)	CASTROL ALPHASYN EP 320 (SYNTHETIC) OR EQUIVALENT	650 ml
*1250MM SLIDE SHIFT FRAME (SL-000225)		
▲ 1500MM MULTIFIT (SL-000002)	CASTROL ISO SP 320 (MINERAL) OR EQUIVALENT	250 ml
▲ 1500MM SIDE SHIFT SLIDE FRAME (SL-000103)		
▲ 1500MM EXCAVATOR MOUNT (SL-000153)		
▲ 1500MM SIDE SHIFT SLIDE FRAME C/W EXCAVATOR MOUNT (SL-000165)		
▲ 1500MM SIDE SHIFT FRAME (SL-000267)		
▲ 1800MM MULTIFIT (SL-000170 / SL-000255)		
▲ 1800MM SIDE SHIFT SLIDE FRAME (SL-000228)		
▲ 1800MM MULTIFIT HEAVY DUTY PICK UP (SL-000283)		

\* This symbol only refers to slashers which use a planetary drive gearbox. ▲ This symbol only refers to slashers which are direct drive units.

**With all slashers, to inspect and change the oil is recommended to be done by a Digga Authorised Service Agent. However if that is not possible, please refer to the Digga document PM-000151.**

PLACEMENT OR REPLACEMENT OF SAFETY SIGNS

1. Clean the area of application with non-flammable solvent, then wash the same area with soap & water.
2. Allow the surface to fully dry.
3. Remove the backing from the safety sign, exposing the backing surface.
4. Apply the safety sign to the position shown in the diagram above and smooth out any bubbles.

INSTRUCTIONS

- Keep all safety signs clean and legible.
- Replace all missing, illegible, or damaged safety signs.
- Replacement parts for parts with safety signs attached must also have safety signs attached.
- Safety signs are available from your dealer or from Digga Australia.

ITEM NO	ORDER CODE	DESCRIPTION	QTY
1	DE-000168	Serial Tag	1
2	DE-000039	Caution: Op Manaul	2
3	DE-000083	Caution: Slasher Riding	2
4	DE-000079	Caution: 15m Distance	2
5	DE-000130	Warning: Slasha Tilts	1
6	DE-000066	Slasha By Digga	2
7	DE-000258	Danger Rotating Blade	2
8	DE-000257	Hearing & Eye Protection	2
9	DE-000049	Digga Logo	2

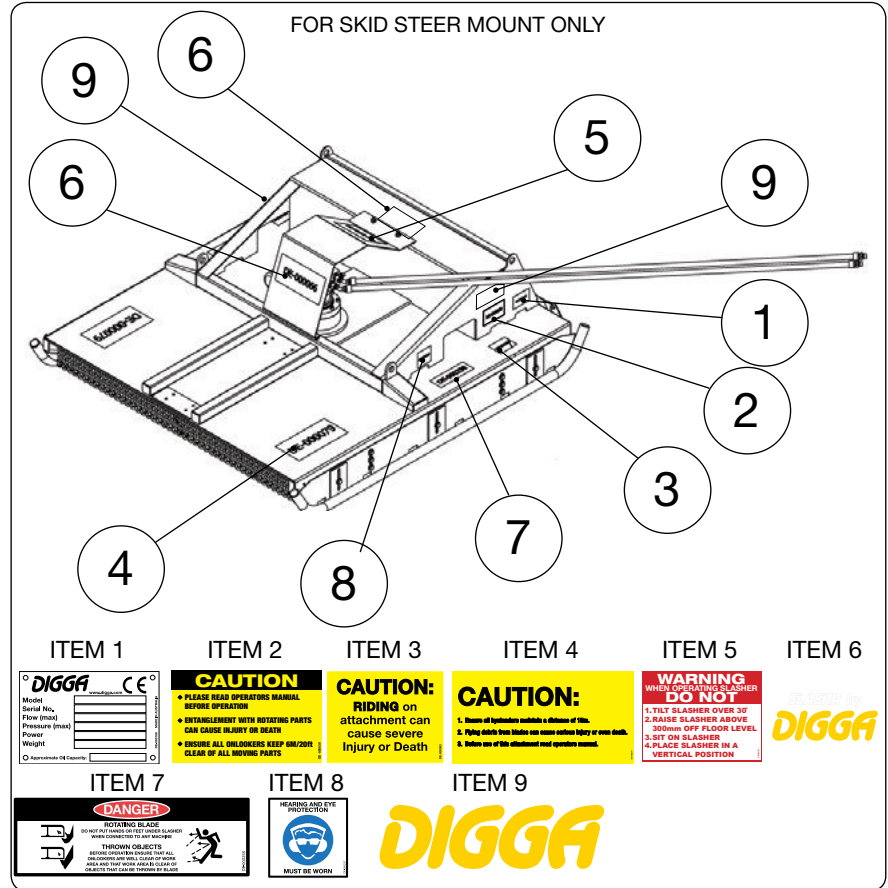

## 9 SAFETY - STICKER LOCATION

### PLACEMENT OR REPLACEMENT OF SAFETY SIGNS

1. Clean the area of application with non-flammable solvent, then wash the same area with soap & water.
2. Allow the surface to fully dry.
3. Remove the backing from the safety sign, exposing the backing surface.
4. Apply the safety sign to the position shown in the diagram above and smooth out any bubbles.

### INSTRUCTIONS

- Keep all safety signs clean and legible.
- Replace all missing, illegible, or damaged safety signs.
- Replacement parts for parts with safety signs attached must also have safety signs attached.
- Safety signs are available from your dealer or from Digga Australia.

ITEM NO	ORDER CODE	DESCRIPTION	QTY
1	DE-000168	Serial Tag	1
2	DE-000039	Caution: Op Manaul	2
3	DE-000083	Caution: Slasher Riding	2
4	DE-000079	Caution: 15m Distance	2
5	DE-000130	Warning: Slasha Tilts	1
6	DE-000066	Slasha By Digga	2
7	DE-000258	Danger Rotating Blade	2
8	DE-000257	Hearing & Eye Protection	2
9	DE-000049	Digga Logo	2

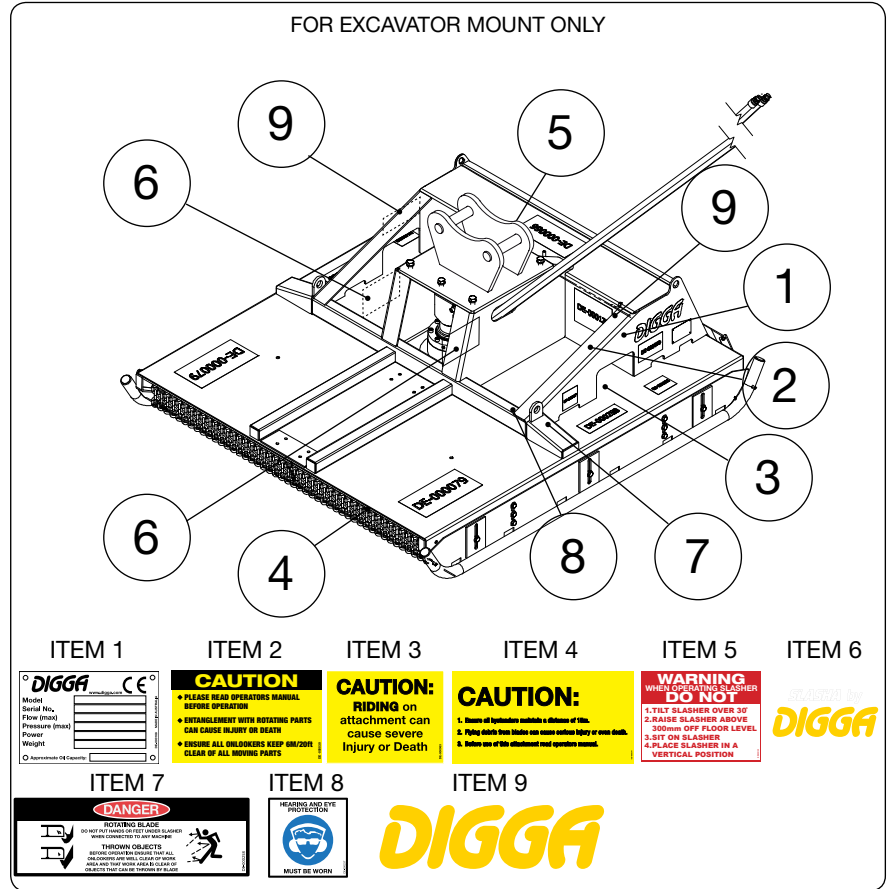

SLASHER		
TROUBLE	POSSIBLE CAUSE	REMEDY
Cutting Blades Stalling	Debris around the blades	Remove Debris/Ensure that safety wire is not broken causing blade entanglement.
	Going to fast through thick/long material	Adjust Travelling/RPM Speed OR make smaller passes.
	Cutting Blade Blunt	Check, sharpen or replace as required.
	Cutting Blades Bent/Damaged	Check and Replace.
Loss of Hydraulic oil	Motor Output Seal	Inspect for any hydraulic oil leaks, repair as necessary, replenish lost oil.
	Loose hydraulic connections on motor	
Loss of Gearbox oil (Only SL-000225 and SL-000227 Slasher models)	Debris have damaged the gearbox output shaft seal OR a faulty or worn hydraulic motor output shaft seal can cause hydraulic oil to contaminate, flood the gearbox oil and in some instances may cause the gearbox output shaft seal to dislodge.	Inspect for any signs of gearbox oil leaks, repair as necessary, replenish lost oil.
Loss of Hydraulic oil	A faulty or worn hydraulic motor output shaft seal can cause hydraulic oil to contaminate, flood the gearbox oil and in some instances may cause the gearbox output shaft seal to dislodge.	Replace hydraulic motor output shaft seal. Drain contaminated gearbox oil. Replace new gearbox oil into gearbox.

# 11 TECHNICAL SPECIFICATIONS

	1250MM M/F (SL-000227)	1250MM SIDE SHIFT SLIDE FRAME (SL-000225)	1500MM M/F (SL-000002)	1500MM SIDE SHIFT SLIDE FRAME (SL-000103)	1500MM C/W EXCAVATOR MOUNT (SL-000153)	1500MM SIDE SHIFT SLIDE FRAME C/W EXCAVATOR MOUNT (SL-000165)	1500MM C/W 3PT.LINKAGE	1800MM M/F (SL-000170)	1800MM SIDE SHIFT SLIDE FRAME (SL-000228)	1800MM 3PT. LINKAGE
Overall Length (mm) excluding jockey wheel	1640	1640	1860	1860	1860	1860	2100	2115	2115	2355
Overall Width (mm)	1425	1425	1650	1650	1650	1650	1650	1930	1930	1930
Overall Height (mm)	600	600	650	650	650	650	650	700	700	700
Mass (kgs)	321	315	363	395	391	420.15	454.5	448.13	482	507.63
Width of cut (mm)	1250	1250	1500	1500	1500	1500	1500	1800	1800	1800
Hydraulic Motor Size (ins)	6	6	4.9	4.9	4.9	4.9	4.9	4.9	4.9	4.9
Gearbox Oil Qty (ml)	650	650	250	250	250	250	250	250	250	250
Type Of Gearbox Oil (recommended)	<b>CASTROL ALPHASYN EP 320 (SYNTHETIC) OR EQUIVALENT</b>		<b>CASTROL ISO SP 320 (MINERAL) OR EQUIVALENT</b>							
Operating Pressure (max) (Bar/PSI)	240/3500	240/3500	240/3500	240/3500	240/3500	240/3500	240/3500	240/3500	240/3500	240/3500
Oil Flow (max) (Litres/Min) (Continuous)	75	75	75	75	75	75	75	75	75	75
Oil Flow (max) (Litres/Min) (Intermittent)	95	95	75	75	75	75	75	75	75	75
Oil Flow Recommended (Litres/Min)	20-40	30-75	30-75	30-75	30-75	30-75	30-75	30-75	30-75	30-75

**For additional safety information please see Risk Management booklet. To obtain a copy contact Digga Head Office on 07 3807 3330**

## WARRANTY

All new Digga products are warranted to be free from defects in materials or workmanship, for a period of twelve (12) months from date of original purchase, which may cause failure under normal usage and service when used for the purpose intended. In the event of failure within twelve (12) months from initial retail sale, lease or rental date (excluding cable, ground engaging parts such as sprockets, digging chain, bearings, teeth, tamping and demolition heads, blade cutting edges, pilot bits, auger teeth, auger heads & broom bristles), if after examination, Digga determines failure was due to defective material and/or workmanship, parts only will be repaired or replaced. Digga may request defective product or products be returned prepaid to them for inspection at their place of business at 4 Octal Street Yatala, Queensland, or to a location specified by Digga. The warranty will be considered void if the product or any part of the product is modified or repaired in any way not expressly authorized by Digga, or if closed components are disassembled prior to return. Closed components include, but are not limited to: gearboxes, hydraulic pumps, motors, cylinders and actuators. Any goods returned to Digga by the customer under warranty or repair must have all freight charges prepaid for on the customers account. Any claims under this warranty must be made within fifteen (15) days after the Buyer learns of the facts upon which such claim is based. All claims not made in writing and received by Digga outside the time period specified above shall be deemed waived.

THIS WARRANTY IS IN LIEU OF ALL OTHER WARRANTIES EXPRESSED OR IMPLIED AND THERE ARE NO WARRANTIES OF MERCHANTABILITY OR OF FITNESS FOR A PARTICULAR PURPOSE. IN NO EVENT SHALL DIGGA BE LIABLE FOR CONSEQUENTIAL OR SPECIAL DAMAGE. DIGGA'S LIABILITY FOR ANY AND ALL LOSSES AND DAMAGES TO BUYER, RESULTING FROM ANY CAUSE WHATSOEVER, INCLUDING DIGGA'S NEGLIGENCE, IRRESPECTIVE OF WHETHER SUCH DEFECTS ARE DISCOVERABLE OR LATENT, SHALL IN NO EVENT EXCEED THE PURCHASE PRICE OF THE PARTICULAR PRODUCTS WITH RESPECT TO WHICH LOSSES OR DAMAGES ARE CLAIMED, OR, AT THE ELECTION OF DIGGA, THE REPAIR OR REPLACEMENT OF DEFECTIVE OR DAMAGED PRODUCTS.



Australian Designed and Manufactured